

VARMEGA - Ceramic countertop basin 500 mm



Finish



Packaging dimensions and weight

Length (mm)	400
Depth (mm)	510
Height (mm)	130
Net weight (kg)	11
Gross weight (kg)	12

Technical Characteristics

- White porcelain integrated basin.
- Resistant to chemical products and scratching.
- Recyclable.
- Syphon, pop-up drain stopper and tap not included.

Basin Dimensions

* ± 5 mm

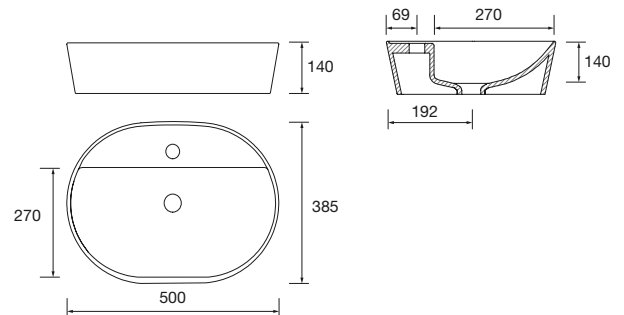

Vanity top machining

* To see more machining options for countertops, consult the Drill Guide.

